

HW65A

WHEELED EXCAVATOR



Gross Power
48.5 kW (65.9 hp) at 2400 rpm

Bucket Capacity
0.07 to 0.18 m³

Operating Weight
6065 to 6485 kg

PRODUCTIVITY & PERFORMANCE

The highly efficient Stage V Hyundai engine enhances fuel efficiency yet still offers industry-leading performance, along with low noise and vibration. And thanks to its optimised design and counterweight, the HW65A has the best work stability in its class.

Greater efficiency

The new Hyundai engine increases fuel efficiency by 6% compared to the previous model, while having the highest torque in its class. And with a DOC + DPF installed, it doesn't need any extra additives.

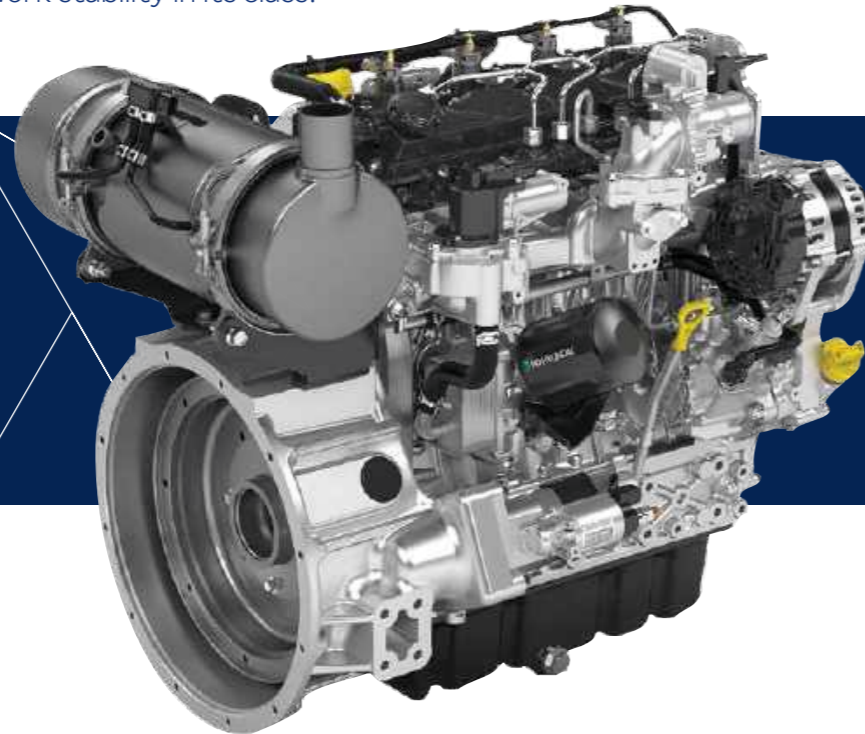

The high-powered Stage V Hyundai DM02V engine delivers 66 HP and peak torque of 248 Nm.



Optimal counterweight

Lifting force has been increased massively by installing a heavy counterweight. It also enables the best working stability in its class.

Improved engine cowl air vent

Increasing the vent hole of the engine cowl by 76% has improved engine cooling and durability and reduced noise.

Reinforced bushing application

Durability is enhanced by applying dimple bushing to the boom pin area.

Complete durability

A double layer air cleaner blocks dust from the engine, which optimises the air filter replacement and the engine's durability.

A 4-way hydraulic line provides greater versatility for the operator allowing a greater use of attachments.



6%
INCREASED
FUEL EFFICIENCY

Built for tough working

The HW65A is designed to withstand harsh treatment, dozer, boom and engine hood guarding give extra protection.

Double tyre option

The HW65A has a double tyre option that gives the machine greater stability. And with a maximum width of 2,100mm, the double tyre option still allows the machine to be transported easily.

Optimal hydraulic pipeline layout

The hydraulic pipes are placed at the top of the boom to prevent damage when working in narrow trenches.

Seamless performance

By designing everything in-house, Hyundai has created the perfect synergy between engine and machine, with reduced noise and vibration enhancing operator comfort.

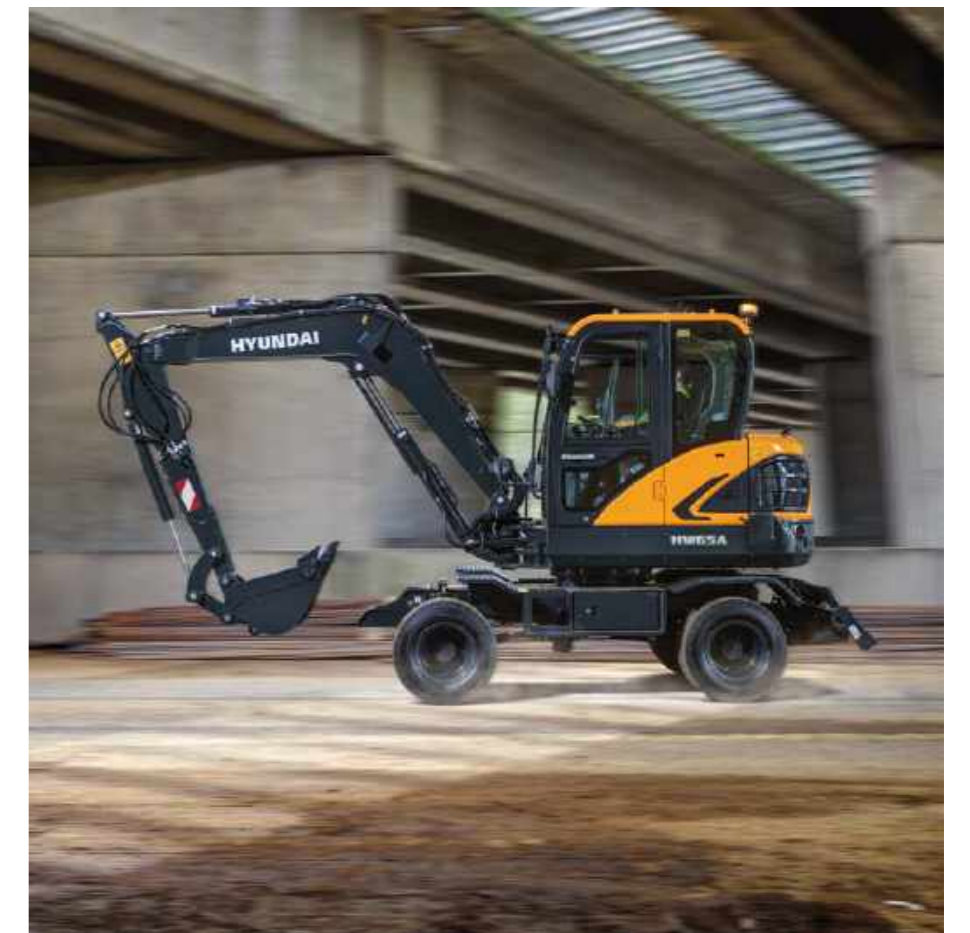

COMFORT & EASE OF USE

In the new HW65A, comfort and efficiency go hand in hand. The standard proportional joysticks improve operating while the new 7-inch cluster makes diagnosing your machine as easy as possible. More space, better visibility and enhanced features make sure the operator enjoys a comfortable working environment.

Intelligent & wide cluster

The new layout increases the operator's comfort and productivity thanks to an increase in space, better visibility and new tools.

✔ New 7-inch touchscreen cluster

The new cluster maximises operator productivity by providing integrated, easy access to all necessary information, from the outside temperature to the power modes and hydraulics settings, on a highly readable screen.



☞ Comfort in all weathers

Standard air conditioning has been improved in the front and rear, while a 3-level, adjustable heated seat ensures maximum comfort.

Proportional joysticks **A**

The proportional joysticks as standard will greatly improve the operability of your machine and your attachments.

Smooth operation

A proven, high-quality RCV (Remote Control Valve) lever has been added to improve operating and let you personalise settings such as attachment control.

Bluetooth Radio **B**

Audio and hands free functions are conveniently located.



☞ Push button start

An innovative machine requires convenient modern functions like the button-type ignition key with start & stop function, plus added USB ports.

SAFETY

Hyundai excavators don't just meet the required safety standards, they exceed them. The HW65A includes multiple safety tools as standard like Auto safety locks on boom, arm and dozer blade cylinder, while a rear view camera ensures the safest working environment possible.

Max visibility

Visibility is key while working. That's why the HW65A is equipped with a rear-view camera as standard with the option of a side-view camera.



Rear-view camera as standard



LED lamps

For added safety, LED lamps are used in all the worklights with the boom worklights recessed to help prevent damage when working.

Seat belt warning alarm

If the seat belt is not buckled when the ignition key is turned, an alarm is sounded, along with a continuous visual alert.

Auto Safety Lock

The Auto Safety Lock prevents unintended operation due to the excavator not being controlled solely by the RCV lever.



SERVICEABILITY & TELEMATICS

The HW65A is designed to offer simple daily inspections of all major parts and quick, easy maintenance. All parts are accessible from ground level through extra wide opening cowl doors.



Optimal placement of filters

Large engine hood and easy ground level access to daily checks and filters.

Reinforced Bushings

Dimple bushings on the boom pins reinforce durability and extend the grease-period of the machine.

Added Toolbox

Increased storage space with additional toolbox.

Double air cleaners

Dual air cleaners give increased filtration ensuring maximum engine life and long service intervals.

Keeping you covered

Hyundai Genuine Parts and accessories are designed to keep your machine running at optimum performance, with 24-hour delivery across our dealer network. Hyundai Standard and Extended Warranty Programmes provide peace of mind and give you full control over your operating costs.



Hi MATE

It's convenient, easy and valuable. Hi MATE, Hyundai's remote management system, utilises GPS-satellite technology to provide customers with the highest level of service and product support available.

Increase productivity

By providing information such as service hours, idle time and fuel consumption, Hi MATE saves you money and improves productivity. Service alerts enable better maintenance planning.

Monitor your machines

Hi MATE's real-time location information allows convenient monitoring of your equipment via the Hi MATE website or mobile app.

Improve Security

Protect your equipment from theft or unauthorised usage. Hi MATE's geofencing alerts notify you automatically when a machine leaves a predetermined zone.

ECD (Engine Connected Diagnostics)

ECD provides troubleshooting information as well as tailored servicing. Service technicians are supported with remote diagnostics allowing them to achieve quick resolution rate.

Mobile fleet app

Our Mobile Fleet app provides all the information you need to run your fleet efficiently and economically.



HCE-DT Air allows service technicians to connect to your equipment wirelessly via smartphone and laptop right on site.

HW65A SPECIFICATIONS

SPECIFICATIONS	HW65A
ENGINE	
Maker / Model	DM02VB HCE / D24
Type	4-cycle, turbocharged, intercooled, electronic controlled diesel engine
Gross Power @ 2400 rpm	48.5 kW (65.9 hp)
Net Power @ 2400 rpm	47 kW (63.9 hp)
Max. Power @ 2400 rpm	48.5 kW (65.9 hp)
Peak Torque	248 Nm
Displacement	2,392 ℓ
Starting Motor	12V x 2.5 kW
Alternator	13.5V-90A

HYDRAULIC SYSTEM	
Open Centre hydraulic system with two hydraulic pumps	
MAIN PUMP	
Type	Variable displacement tandem axial piston pumps
Max. flow	2 x 60 l/min
PILOT PUMP	
Type	Two gear pumps (pilot + swing, swivel, dozer)
Max. flow	38.9 + 9.5 l/min

HYDRAULIC MOTORS	
Travel	Two fixed displacement axial piston motors
Swing	Axial piston motor with automatic brake

RELIEF VALVE SETTING	
Implement circuits	220 kgf/cm ² (3130 psi)
Travel	350 kgf/cm ² (4980 psi)
Swing circuit	230 kgf/cm ² (3280 psi)
Pilot circuit	220 kgf/cm ² (3130 psi)

HYDRAULIC CYLINDERS		
No. of cylinder bore x stroke	Arm:	1-115 x 1138 mm
	Bucket:	1-100 x 850 mm
	Blade:	2-110 x 235 mm
	Outrigger:	2-125 x 463 mm
	Monoboam:	1-105 x 1105 mm

DRIVES & BRAKES	
Drive method	Two-speed powershift transmission with 4-wheel hydrostatic drive travel motor and parking brake
Max. Drawbar Pull	3042 kgf
Max. Travel Speed (High / Low)	11 km/h - 32 or 20 km/h
Gradeability	30° (58%)
Parking Brake	Multi Wet Disc

CONTROLS	
Pilot pressure operated joysticks, steering wheel and foot pedals for effortless operation.	
Pilot control	Two joysticks with One Safety Lever (LH): Swing and Arm, (RH): Boom
Engine throttle	Electric, Dial Type

AXLE & WHEELS	
4-wheel drive with differential. Full floating front axle supported by center pin for oscillation. Rear axle fixed on the lower chassis. Oscillation lock (ram lock) function for safe operation.	
Single tyres	12.0 x 16.5-12PR
Twin tyres (standard)	700 X 15-16PR

STEERING SYSTEM	
Hydraulically actuated orbital type actuates on front wheels through steering cylinders	
Min. Turning Radius	5450 mm (single/twin tyres)

SPECIFICATIONS	HW65A
SWING SYSTEM	
Swing motor	Fixed displacement axial piston motor
Swing reduction	2-stage planetary
Swing bearing lubrication	Grease-bathed
Swing brake	Multi wet disc
Swing speed	8.3 rpm

CAPACITIES	
	liter
Fuel tank	125
Engine coolant	11
Engine oil	8.6
Swing device	1.5
Final drive	1
Hydraulic system (including tank)	120
Hydraulic tank	70

UNDERCARRIAGE	
Rigid, welded frame, transmission and rear differential protection, heavy duty axles for dual tyres.	
Dozer blade	
Width x height:	1925 x 350 mm
Max. lift height above ground level:	430 mm
Max. depth below ground level:	154 mm

OPERATING WEIGHT				
Operating weight, including 3000 mm mono boom, SAE heaped 0.18 m ³ bucket, lubricant, coolant, full fuel tank, full hydraulic tank and all standard equipment.				
Equipment options	Operating weight			
Std arm (1.60 m)	•	•	•	•
Long arm (1.90 m)			•	•
Std counterweight (210kg)	•	•	•	•
Additional counterweight (330kg)			•	•
Single tyres	•	•	•	•
Dual tyres		•	•	•
Machine weight (kg)	6065	6355	6195	6485

AIR CONDITIONING SYSTEM	
The air conditioning system contains fluorinated greenhouse gas refrigerant R134a (Global Warming Potential = 1430). The system contains 0.65 kg of refrigerant representing a CO ₂ equivalent of 0.93 metric tonnes.	

HW65A DIMENSIONS & WORKING RANGE

HW65A MONO BOOM DIMENSIONS

3.0 Mono boom, 1.6m, 1.9m Arm, Front dozer

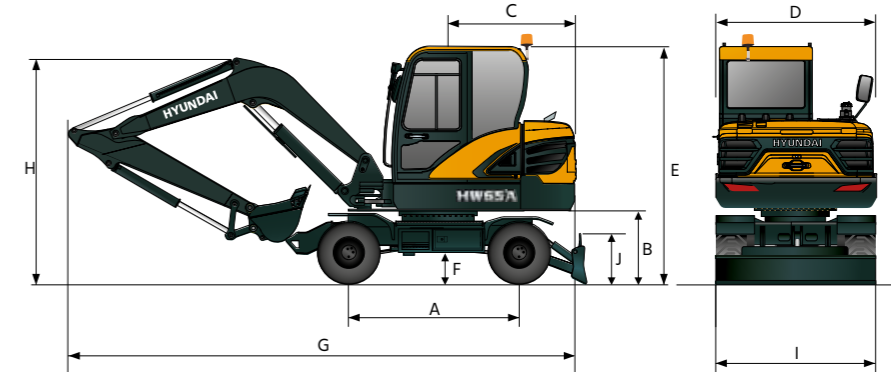

Unit : mm

A	Wheel base	2100
B	Ground clearance of upper structure	1000
C	Tail swing radius	1680
D	Overall width of upper structure	1925
E	Overall height of cab	2905
F	Min. Ground clearance	315

Boom length	3000	
Arm length	1600	1900
G Overall length	6200	6060
H Overall height of boom	2800	3070
I Overall width (double tire)	1925 (2100)	
J Height of blade	350	

HW65A WORKING RANGE

Unit : mm

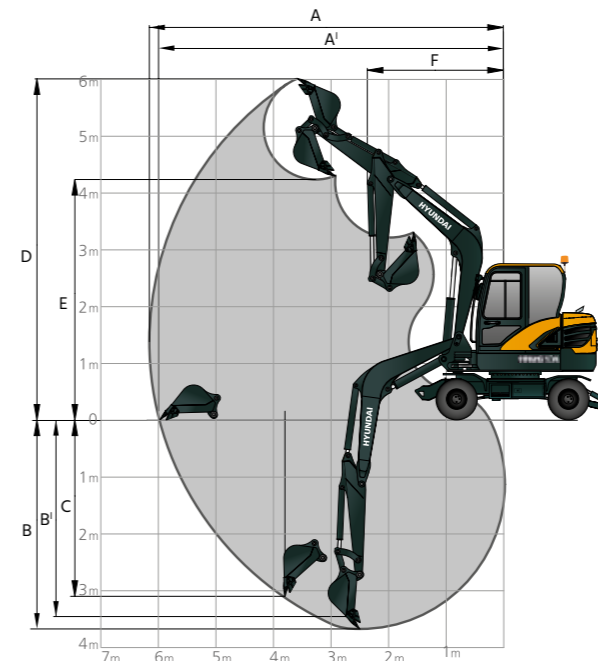

Boom length	3000	
Arm length	1600	1900
A Max. digging reach	6150	6450
A' Max. digging reach (ground)	5950	6250
B Max. digging depth	3490	3790
B' Max. digging depth (8ft level)	3100	3440
C Max. vertical wall digging	3950	3320
D Max. digging height	6045	6260
E Max. dumping height	4290	4490
F Min. swing radius	2380	2410



HYUNDAI



HD Hyundai Construction Equipment Europe nv, Hyundailaan 4,
3980 Tessenderlo, Belgium. Tel: (32) 14-56-2200 Fax: (32) 14-59-3405

Specifications and design are subject to change without notice.
Pictures of Hyundai Construction Equipment Europe products may
show other than standard equipment.

READY TO CHANGE YOUR WORLD?

Contact your Hyundai dealer.
hyundai-ce.eu/en/dealer-locator