



# QA441 DOUBLESREEN ENGINEERING IN MOTION

## TECHNICAL SPECIFICATIONS

KEY SPECIFICATIONS	DATA
Screen	
Type	2 off screenboxes, 2 Bearing 2 Deck
Screen box size	20' x 5' / 6 x 1.5 m
Tensioning system	Manual Ratchet
Speed	1200 rpm
Throw	7.24 mm
Motor	49.1 cc x 2 off

KEY SPECIFICATIONS	DATA
Power pack	
Engine	CAT C4.4 74.5 kw / 100 hp
Diesel tank size	290 litres / 76.5 USG
Hydraulic tank size	370 litres / 98 USG

Note. All weights and dimensions are for standard units only

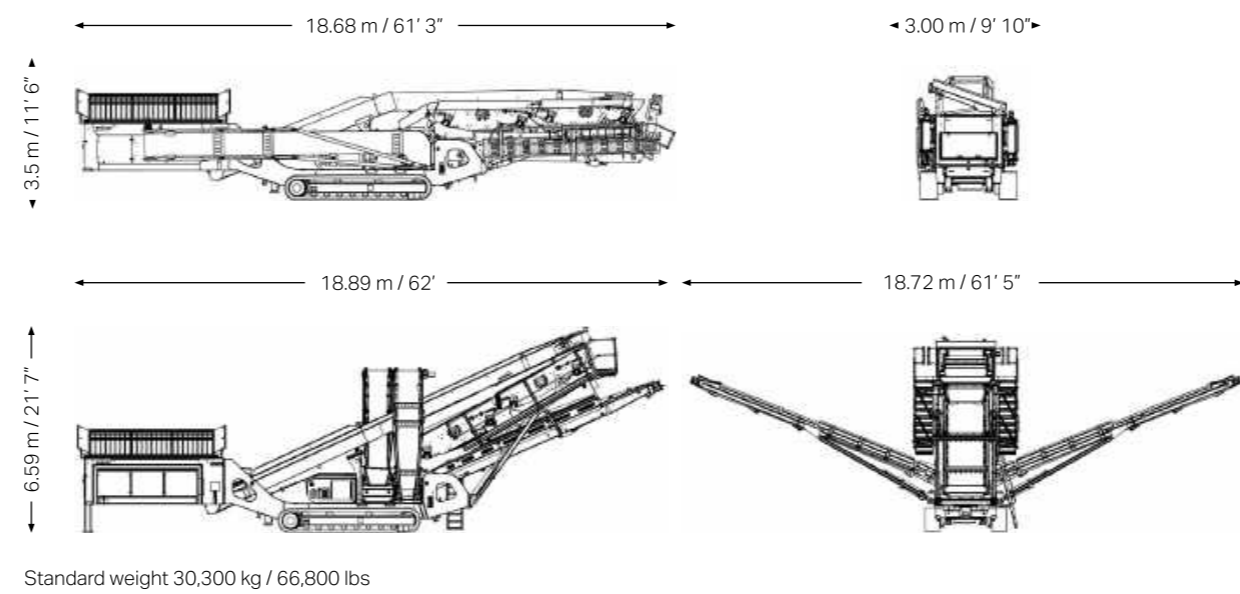

At the heart of the QA441 is the Patented Doublescreen box, featuring two independent double deck screen boxes. The primary screen works as a fines extractor, whilst the secondary screen operates as a grader. Two processes combined on one plant, both primary & secondary screening angles can be adjusted relative to each other. The QA441 offers a screening solution no other mobile double deck screener can provide as its two screen boxes offer an unsurpassed level of separation on a wide range of materials, at very high rates of production.



- ① First screen box is used as a fines extractor
- ② The majority of the undersize is removed during initial impact
- ③ Second box operates as a grader
- ④ Clean gradings, at very high output, are produced as material is exposed to a very large screening area



# QA441 DOUBLESREEN ENGINEERING IN MOTION

KEY SPECIFICATIONS	DATA
Screen type	Sandvik Doublescreen 2-Deck
Screen box size	20' x 5' / 6 x 1.5 m
Engine	C4.4 74.5 kW / 100 hp
Transport dimensions	18.68 m / 61' 3" (l) 3.00 m / 9' 10" (w) 3.50 m / 11' 6" (h)
Weight	30,300 kg / 66,800 lbs

## ULTIMATE SCREENING SOLUTION

Featuring the patented, world-class heavy duty Doublescreen screen box from Sandvik, the QA441 is the ideal solution for large-scale aggregates producers requiring large throughput and high screening accuracy.

Two high velocity screens that work independently to each other, the primary screen works as a fines extractor, whilst the secondary screen operates as a grader. Two processes combined on one plant, both primary and secondary screening angles can be adjusted relative to each other.

User-friendly features include an updated feeder hopper & feeder drive, an "easy to use" control system with sequential start-up. The QA441 lends itself to many applications including iron ore, aggregates, topsoil, recycling, minerals, coal, sand and gravel.

### FEATURES INCLUDE:

- High production capabilities due to its phenomenal Doublescreen system - two in-line, independently vibrating 10' x 5' double deck screenboxes.
- Primary screen works as a fines extractor, whilst secondary screen operates as a grader
- Large volume hopper complete with remote control hydraulic tipping grid.
- User friendly control panel with sequential start-up for ease of operation
- Hydraulically folding 3 sided walkways for ease of maintenance
- Wide range of options to suit different applications
- Machine designed for optimum fuel economy and low operating costs.

- ① **Main Conveyor**
- 1000 mm / 3' 3" wide variable speed conveyor
  - Hydraulic raise/lower facility to enable quick mesh change and maintenance

- ② **Screen box**
- Double deck 20' x 5' / 6 m x 1.5 m equivalent patented Doublescreen for high production capabilities
  - Adjustable screen box dependent on the type of screening required
  - Easy-change mesh facility with highly efficient ratchet tensioning system
  - Hydraulically folding three sided walkway for ease of maintenance

- ③ **Side conveyors x 2**
- 700 mm / 27.5" wide belt with a discharge height of 5090 mm / 16' 8" for massive stockpiling capability

- ④ **Hopper**
- Large volume hopper complete with remote control hydraulic tipping grid
  - Variable speed belt feeder, heavy duty-roller bed and belting
  - Heavy duty feeder drive system for large throughput
  - Vibrating grid available as an option

- ⑧ **Fines tail conveyor**
- 1200 mm / 47" wide belt with a discharge height of 4988 mm / 16' 4" for massive fines stockpiling capability

- ⑦ **Chassis**
- Hydraulic legs for increased stability and servicing capabilities

- ⑥ **Tracks**
- 500 mm / 20" wide tracks driven by radio control as standard for ultimate maneuverability

- ⑤ **Power pack**
- 74.5 kW / 100 hp emissions compliant diesel engine
  - User friendly push button control panel with sequential start-up for ease of operation
  - Easy access to the engine compartment for service and maintenance



### STANDARD FEATURES



Redesigned feeder hopper for easier access



Remote control for ease of mobility



Patented double deck Doublescreen technology



Colour coded control panel for ease of operation



Three sided walkway around main conveyor



Massive stockpiling capabilities